

ONKYO® SERVICE MANUAL

Infrared Wireless Remote Controlled Stereo Preamplifier

MODEL P-301

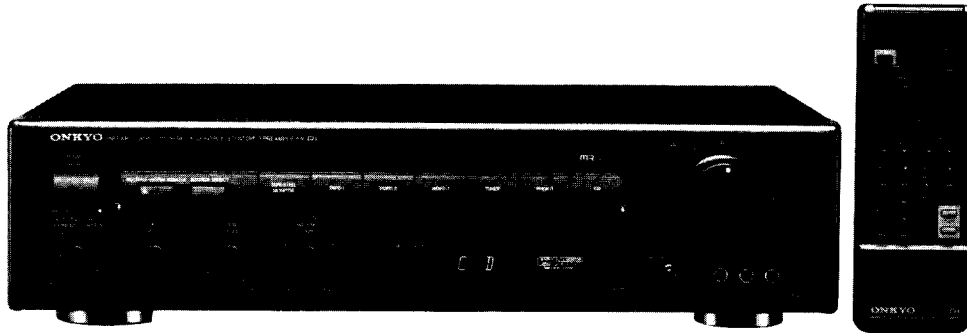

UD	120V AC, 60Hz
----	---------------

SAFETY-RELATED COMPONENT WARNING!!
COMPONENTS IDENTIFIED BY MARK Δ ON THE SCHEMATIC DIAGRAM AND IN THE PARTS LIST ARE CRITICAL FOR RISK OF FIRE AND ELECTRIC SHOCK. REPLACE THESE COMPONENTS WITH ONKYO PARTS WHOSE PARTS NUMBERS APPEAR AS SHOWN IN THIS MANUAL.

MAKE LEAKAGE-CURRENT OR RESISTANCE MEASUREMENTS TO DETERMINE THAT EXPOSED PARTS ARE ACCEPTABLY INSULATED FROM THE SUPPLY CIRCUIT BEFORE RETURNING THE APPLIANCE TO THE CUSTOMER.

TABLE OF CONTENTS

Specifications.....	2
Remote control transmitter.....	2
Block diagram.....	3
IC Block diagram.....	5
Front panel facilities.....	11
Chassis-exploded view.....	12
Printed board parts list.....	14
Packing parts list.....	16
Schematic diagram.....	19
System connections.....	23



SPECIFICATIONS

Rated Output and Impedance: 1V/3.3 Kohms MAX 5V
 Total Harmonic Distortion: 0.009%
 IM Distortion: 0.09%
 Frequency Response: 15 – 30,000 Hz ±1dB
 Sensitivity and Impedance: Phono: 2.5mV/50 kohms
 Tuner, CD, Tape Play
 VCR, VDP Sound: 150mV/50 kohms
 Tape Rec: 150mV/2.2 kohms
 (phono)
 Phono Overload: 120mV RMS at 1 kHz, 0.09% THD
 Bass Control: ±10 dB at 100Hz
 Treble Control: ±10 dB at 10,000 Hz
 Selective Tone Control: +15 dB at 50Hz
 +6 dB at 10,000Hz
 Signal to Noise Ratio: Phono: 83dB (IHF-A, 5mV input, 1 V output)
 Source Direct: 100dB (IHF-A, 1 V output)

General

Power Supply: AC120V, 60Hz
 Dimensions (W x H x D): 455 x 110 x 312mm
 17-15/16" x 4-3/8" x 12-1/4"
 Weight: 4.1kg, 9.0 lbs.

Remote control transmitter RC-200S

Transmitter: Infrared
 Signal range: Approx. 5meters (16ft.4")
 Power supply: Two "AA" batteries (1.5V x 2)

Specifications and features are subject to change without notice.

REMOTE CONTROL TRANSMITTER

System Power Button (POWER)

This button has the same function as the POWER button on the front panel.

Input Selector Buttons (TUNER, PHONO, CD, TAPE-2, TAPE-1, VIDEO-2, VIDEO-1)

These buttons have the same functions as the input selector buttons on the front panel.
 NOTE: The AUX button does not operate on the P-301.

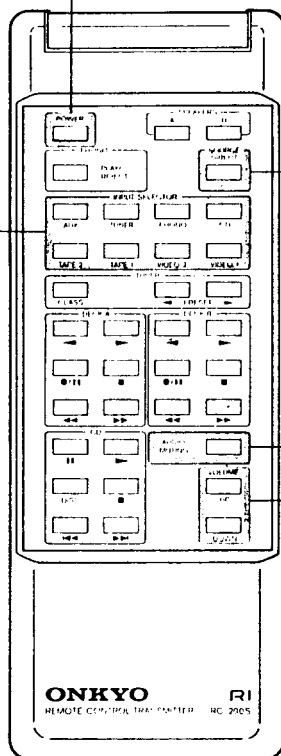

Source Direct Button (SOURCE DIRECT)

This button has the same function as the SOURCE DIRECT button on the front panel.

Audio Muting Button (AUDIO MUTING) and Indicator

This button temporarily switches off the sound from the speaker or headphone. Pressing this button will operate the P-301's audio muting circuit. The audio muting indicator [MUTING] will light. Pressing the button again will turn off the audio muting. This function can be operated with the remote control transmitter only.

Volume Buttons (▲ UP, ▼ DOWN)

These buttons have the same function as that of the volume control. The volume level can be adjusted by pressing the UP or DOWN button, with the volume control knob rotating simultaneously.

BLOCK DIAGRAM

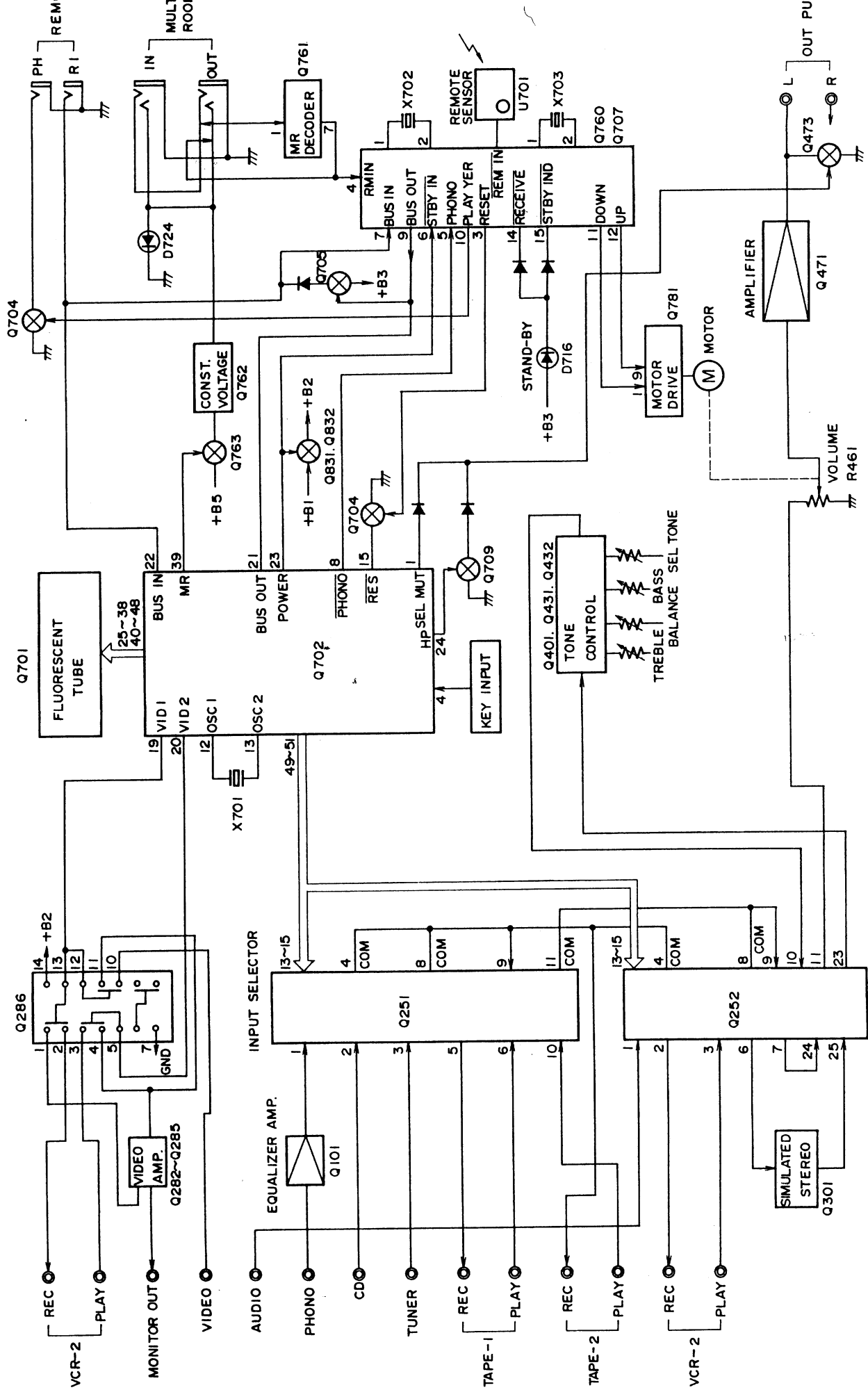

IC BLOCK DIAGRAM AND DESCRIPTIONS

LC65204A-4605 (Microprocessor)
LC65204A

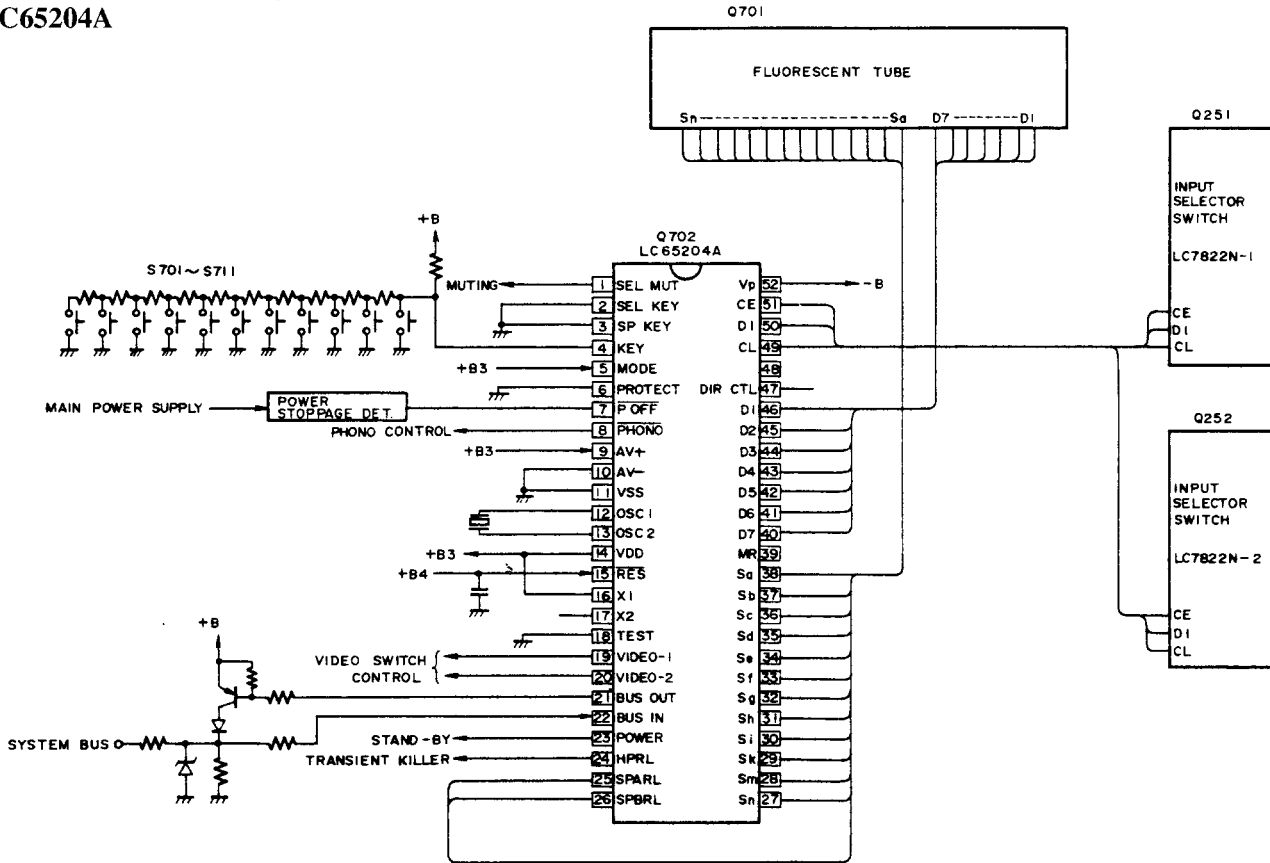

Pin No.	Pin name	Symobl	Function
1	PA0/ADO	SEL MUT	Output terminal for muting when changing over Input Selector to the like. Active "H".
2	PA1/AD1	SELKEY	Input terminal for switch when changing over Input Selector. Effective exclusively when MODE = 0. In case of MODE = 1, connect to GND (Ground). Through A/D conversion, the selector will be detected on its right or left rotation.
3	PA2/AD2	SPKEY	Input terminal for switch when cahnging over Speaker. Effective exclusively when MODE = 0. In case of MODE = 1, connect to GND. The position of Rotary Switch will be fetched by A/D conversion.
4	PA3/AD3/INT1	KEY	Key entry terminal Momentary Key will be fetched by A/D conversion.
5	PB0/AD4/DAC0	MODE	Input terminal for initialization to change over operation mode.
6	PB1/AD5/DAC1	PROTECT	Input terminal for detecting Protect Operation. Active "H". However, "H" 100μs or under shal be ignored.
7	PB2/AD6/SQR	POFF	Input terminal for detecting power suspension. Active "L". However, "L" 100μs or under shall be ignored.
8	PB3/AD7/START	PHONO	Output terminal for controlling PHONO. TO be "L" when set Selector at PHONO.
9	AV+	AV+	Input terminal for the referential electric current and voltage in case of A/D conversion.
10	AV-	AV-	
11	Vss	Vss	GND terminal.

Pin No.	Pin name	Symobl	Function
12	OSC1	OSC1	The terminal composing oscillator circuit for the System Main Clock. Ceramic oscillator of 4. 4.00MHz shall be connected.
13	OSC2	OSC2	
14	V _{DD}	V _{DD}	Power source (+5V) terminal.
15	$\overline{\text{RES}}$	$\overline{\text{RES}}$	Input terminal for system reset. Active "L".
16	X1	X1	The terminal composing oscillator circuit for the System Subclock. Not used and X1 shall be connected with V _{DD} to leave X2 open.
17	X2	X2	
18	TEST	TEST	Test terminal for LSI. To be connected to V _{SS} .
19	PFO/SI	VIDEO-1	Output terminal for controlling the picture signal of VIDEO-1. TO be "L" when set the selector at VIDEO-1.
20	PF1/SO	VIDEO-2	Output terminal for controlling the picture signal of VIDEO-2. To be "L" when set the selector at VIDEO-2.
21	PF2/ $\overline{\text{SCK}}$	$\overline{\text{SYS OUT/SYS EN}}$	Output terminal for System Code. Active "L". When turned on the power source. Initialized input SYS EN Will be displayed to change-over operation such as System Code. When SYS EN = 0 this input shall be left "H" (input).
22	PF3/INTO	SYS IN	Input terminal for System Code. Active "H".
23	PCO	POWER	Output terminal for controlling POWER. To be "H" when POWER ON.
24	PC1	HPRL	Output terminal for controlling HEAD PHONE Relay. "H" when turned ON.
25	PC2	SPARL/Sr	In case of MODE = 0. Output terminal for controlling SPEAKER A Relay. "H" when turned ON. In case of MODE = 1. Output terminal for Segment Sp. Active "H".
26	PC3	SPBRL/Sp	In case of MODE = 0. Output terminal for controlling SPEAKER B Relay. "H" when turned ON. In case of MODE = 1. Output terminal for Segment Sp. Active "H".
27	PD0	Sn	Output terminal for Segment (Sn – Sd). Effective exclusively when MODE = 1. Active "H". In case of MODE = 0, not to used and "L" will be output at any time.
28	PD1	Sm	
29	PD2	Sk	
30	PD3	Sj	
31	PK0	Sh	
32	PK1	Sg	
33	PK2	Sf	
34	PK3	Se	
35	PL0	Sd	
36	PL1	MUTING/Sc	In case of MODE = 0 Output terminal for displaying MUTING. In case MUTING ON of the remote control; "H" (light). In case of MODE = 1 Output terminal for Segment Sc. Active "H".
37	PL2	SPB/Sb	In case of MODE = 0 Output terminal for displaying SPB (Speaker B Relay). When set Speaker to be changed-over at B or A+B, or selected SPEAKER-B by remote control with Speaker set at MR; "H" (light) In case of MODE = 1 Output terminal for Segment Sb. Active "H".
38	PL3	SPA/Sa	In case of MODE = 0 Output terminal for displaying SPA (Speaker A Relay). When set Speaker to be changed-over at A or A+B, or selected SPEAKER-A by remote control with Speaker set at MR; "H" (lighted). In case of MODE = 1 Output terminal for Segment Sa. Active "H".

μPD17103CX-528 (Remote Control Decoder)

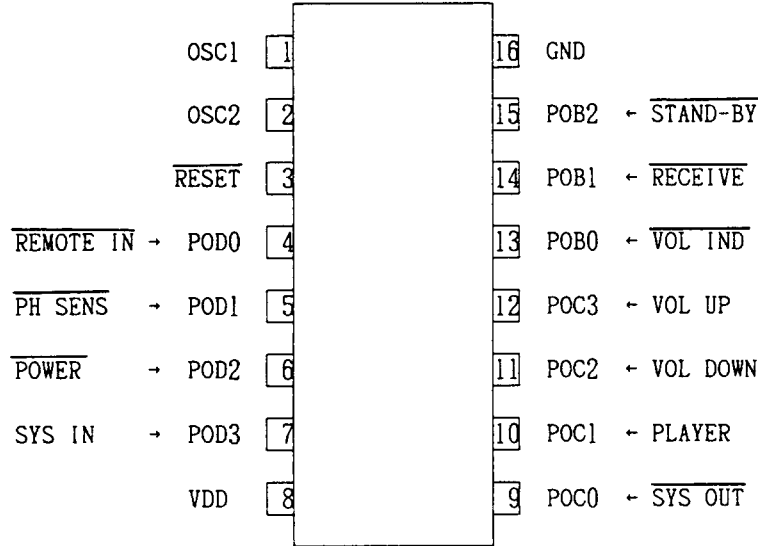
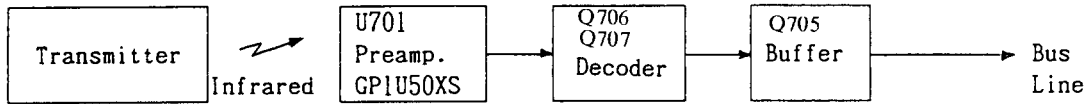

Pin No.	Symbol	Terminal	Description
1	OSC1	OSC	Connect to the 8.00MHz ceramic oscillator.
2	OSC2		
3	RES	<u>RESET</u>	System reset terminal. Active low.
4	POD0	<u>REMOTE IN</u>	Signal input terminal from preamp. for remote control. Active low.
5	POD1	PHONO SENES	Phono detection input terminal. Active low.
6	POD2	POWER	Stand-by detection input terminal. During low input, only the POWER code is decoded.
7	POD3	SYS IN	System code input terminal.
8	V _{DD}	+B	Power supply terminal.
9	POC0	<u>SYS OUT</u>	Output at this terminal are the custom code (16bits) remote control code input to REMOTE IN, data code (8bits), and the serial code (12bits) that has been converted corresponding to the decoded data code (8bits)
10	POC1	PLAYER	When the player PLAY/REEJECT is input, a high pulse of 200ms is output.
11	POC2	VOL DOWN	When the volume DOWN code is input, a high pulse of 120ms is output.
12	POC3	VOL UP	When the volume UP code is input, a high pulse of 120ms is output.
13	POB0	<u>VOL IND</u>	During the output of VOLUME UP/DOWN, a pulse (<u>┌</u> <u>T</u> <u>└</u> <u>T</u> <u>┌</u> <u>T</u> <u>└</u>)= 250ms) is output. (Not used.)
14	POB1	<u>RECEIVE</u>	This is the display output for remote control reception. Output is low when decoded code is being recieved.
15	POB2	<u>STAND-BY</u>	STAND-BY indication terminal.
16	V _{SS}	GND	Ground terminal.

CF1031C (Fluorescent indicator tube)

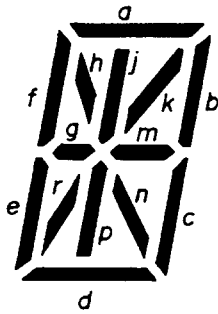
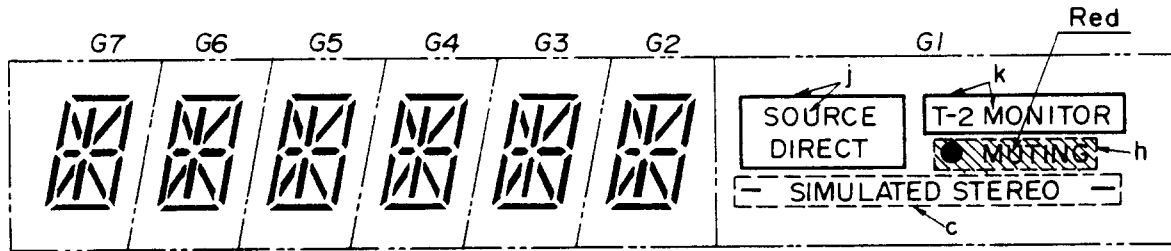
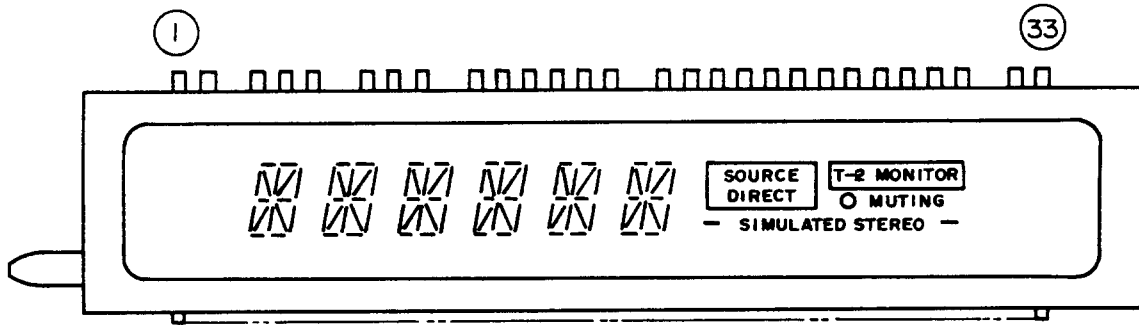

PIN ASSIGNMENT

Pin No.	1	2	3	4	5	6	7	8	9	10	11	12	13	14	15	16	17
Assignment	F	F	NP	e	G7	g	NP	G6	f	G5	NP	h	G4	r	p	G3	d

Pin No.	18	19	20	21	22	23	24	25	26	27	28	29	30	31	32	33
Assignment	NP	G2	a	G1	j	k	G1	b	n	G1	c	m	G1	NP	F	F

F: Filament G1~G7: Grid a~r: Anode NP: No pin

CHASSIS-EXPLODED VIEW

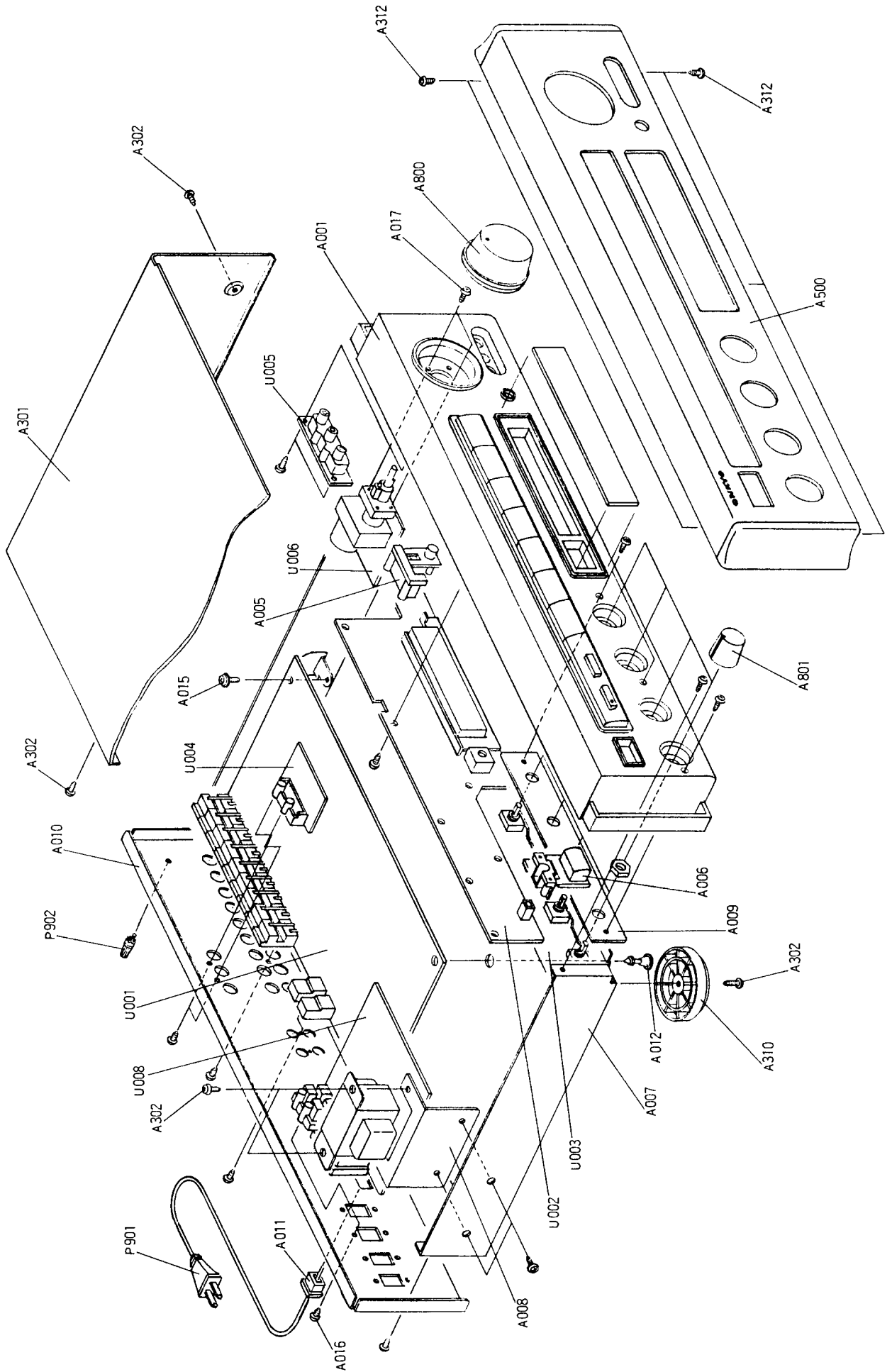

CHASSIS-EXPLODED VIEW-PARTS LIST

REF NO.	PART NO.	DESCRIPTION
A001	27110624A	FRONT BRACKET ASS'Y
(A001b)	28324268	KNOB
(A001c)	28324269	KNOB (SEL)
(A001d)	28324271	BASE (KNOB)
(A001e)	28198759	FACET
(A001f)	28198741	FACET
(A306)	28191588	CLEAR PLATE
A005	28324272	KNOB (SIM)
A006	28324273	KNOB (POW)
A007	27100236	CHASSIS
A008	27141482	BRACKET (PT)
A009	27130649	BRACKET (TONE)
A010	27121416A	BACK PANEL
A011	27300750	BUSHING (CABLE)
A012	27190524	KGLS-14RT, HOLDER
A015	831130088	3TTW+8B, TAP-TIGHT SCREW
A016	833430080	3TTP+8PBC, TAP-TIGHT SCREW
A017	82143006	3P+6FNBC, SCREW
A301	28184478	TOP COVER
A302	834430088	3TTS+8BBC, TAP-TIGHT SCREW
A500	1A256121	FRONT PANEL ASS'Y
(A502)	28125222	END CAP (L)
(A503)	28125223	END CAP (R)
(A504)	28135199	NAME PLATE
A800	28324274	KNOB ASS'Y (VOL)
A801	28324252-1A	KNOB (TON)
A310	27175254	BOTTOM LEG ASS'Y
A312	833430080	3TTP+8BBC, TAP-TIGHT SCREW
▲ P901	253123 or	AS-UC-6 #18, POWER SUPPLY CABLE
	253146	AS-UC-6 #18, POWER SUPPLY CABLE
P902	25060044	GROUND TERMINAL
▲ T901	2300522	NPT-1062D, POWER TRANSFORMER
▲ P902, P903	25050409	NSCT-4P234, AC OUTLET
U001	1A256513-1	NAAF-4113-1, INPUT CIRCUIT PC BOARD ASS'Y
U002	1A256514-1	NADG-4114-1, MICROPROCESSOR CIRCUIT PC BOARD ASS'Y
U003	1A256515-1	NAAF-4115-1, TONE CONTROL CIRCUIT PC BOARD ASS'Y
U004	1A256516-1	NAETC-4116-1, VIDEO CIRCUIT PC BOARD ASS'Y
U005	1A256517-1	NAETC-4117-1, VIDEO INPUT CIRCUIT PC BOARD ASS'Y
U006	1A256518-1	NAETC-4118-1, MOTOR DRIVE CIRCUIT PC BOARD ASS'Y
U008	1A256520-1	NAPS-4120-1, POWER TRANSFORMER CIRCUIT PC BOARD ASS'Y

NOTE:

THE COMPONENTS IDENTIFIED BY MARK ▲ ARE CRITICAL FOR RISK OF FIRE AND ELECTRIC SHOCK. REPLACE ONLY WITH PART NUMBER SPECIFIED.

PRINTED CIRCUIT BOARD-PARTS LIST

INPUT CIRCUIT PC BOARD (NAAF-4113-1)

CIRCUIT NO.	PART NO.	DESCRIPTION	CIRCUIT NO.	PART NO.	DESCRIPTION	
			C916	354761019	100 μ F, 35V, Elect.	
			C919, C921	354742219	220 μ F, 16V, Elect.	
			C934	354722219	220 μ F, 6.3V, Elect.	
			C941	354741009	10 μ F, 16V, Elect.	
				Resistors		
			R911	441622204	22 Ω , 1W, Metal oxide film	
			R912	441526804	68 Ω , 1/2W, Metal oxide film	
			R913, R914	442521324	1.3k Ω , 1/2W, Metal oxide film	
			R915	441521814	180 Ω , 1/2W, Metal oxide film	
			R916	442523904	39 Ω , 1/2W, Metal oxide film	
			R931	441627504	75 Ω , 1W, Metal oxide film	
			R932	442522724	2.7k Ω , 1/2W, Metal oxide film	
			R941	442521524	1.5k Ω , 1/2W, Metal oxide film	
				Switch		
			S801	25065286	NSS-22112 Slide	
				Terminals		
			P801-P803	25045300	NPJ-6PDBL159	
			P806	25045307	NPJ-2PDBL166	
				Jacks		
			P807	25045172	HSJ1003-01-020	
			P808	25045293	HSJ1003-01-012	
				Jumper socket		
			JL401a	25050273	NSCT-9P101	
			JL901a	25050271	NSCT-7P99	
				Radiator		
			Q911a, Q931a	27160211	RAD-68	
				Bracket		
				27141059		
				MICROPROCESSOR CIRCUIT (NADG-4114-1)		
				CIRCUIT NO.	PART NO.	DESCRIPTION
					Photo receiving unit	
			U701	24130003	GPIU50XS	
				FL tube		
			Q701	212095	CF1031C	
				ICs		
			Q702	22240431	LC65204A-4605	
			Q706, Q707	22240376	MPD17103CX-528	
				Transistors		
			Q703, Q704	221281	DTC114YS	
			Q709			
			Q705	2213510	DTA114ES	
			Q708	2211183	2SC1740R	
				Diodes		
			D701, D704	224450562	MTZ5.6B	
			D702, D703	223163	1SS133	
			D705-D715			
			D717-D723			
			D716, D724	225141	SEL-2213C	
				Ceramic osc.		
			X701	3010150	CST4.00MGW	
			X702, X703	3010154	CST8.00MT	
				Capacitors		
			C701, C702	354780339	3.3 μ F, 50V, Elect.	
			C705, C712			
			C703, C706	354741009	10 μ F, 16V, Elect.	
			C708	354780109	1 μ F, 50V, Elect.	

CIRCUIT NO.	PART NO.	DESCRIPTION
C711	3000051	0.047F, 5.5V, Super
Switches		
S701~S711	25035548	NPS-111-S510
Holders		
Q701a	27190659B	(FL)
D716a	27190599	(LED)
D724a	27190740	(LED)

TONE CONTROL CIRCUIT (NAAF-4115-1)

CIRCUIT NO.	PART NO.	DESCRIPTION
ICs		
Q401, Q431 Q432	22240273	NJM4565S-D
Capacitors		
C401, C402	391780229	2.2μF, 50V, Elect. (HWQ)
C405, C406		
C407, C408	354780339	3.3μF, 50V, Elect.
C439, C440		
C431, C432	371128224	8200 pF, 50V, Mylar
C433, C434	354780229	2.2μF, 50V, Elect.
C435, C436	371125134	0.051μF, 50V, Mylar
C441, C442	371122234	0.022μF, 50V, Mylar
C445, C446		
Resistors		
R415	5104225	N11RGLC250KWT22Z
R431(R432)	5104285	N14RGL50KRD22Z
R439(R440)	5104230	N14RLC100KWT22Z
R447(R448)		

VIDEO CIRCUIT PC BOARD (NAETC-4416-1)

CIRCUIT NO.	PART NO.	DESCRIPTION
IC		
Q286	222840661	4066B
Transistors		
Q281~Q284	2211183 or 2211255	2SC1740R or 2SC1815GR
Q285	2213074 or 2211455	2SA933R or 2SA1015GR
Capacitors		
C281, C283	354724719	470μF, 6.3V, Elect.
C282, C284	354741009	10μF, 16V, Elect.
C285		
Socket ass'y		
P281	2000912A	NSAS-4P868
Terminal		
P805	25045299	NPJ-3PDYE158

VIDEO INPUT CIRCUIT PC BOARD (NAETC-4117-1)

CIRCUIT NO.	PART NO.	DESCRIPTION
Terminal		
P804	25045225	NPJ-3PDBL101

MOTOR DRIVE CIRCUIT PC BOARD (NAETC-4118-1)

CIRCUIT NO.	PART NO.	DESCRIPTION
IC		
Q781	22240239	TA7291S
Diode		
D782	223163	1SS133
Capacitor		
C781	354741009	10μF, 16V, Elect.
Resistor		
R461(R462)	5104284	N16RGM50KA25F
Jumper socket		
JL804a	25050269	NSCT-5P97

POWER TRANSFORMER CIRCUIT PC BOARD (NAPS-4120-1)

CIRCUIT NO.	PART NO.	DESCRIPTION
Diode		
D901	223145	1S2076TD
Transformer		
△ T901	2300522	NPT-1062D
Capacitors		
△ C901, C902	3500065A	0.01μF, AC400V/125V, Film(IS)
Resistors		
△ R901, R902	442520154	1.5Ω, 1/2W, Metal oxide film
Relay		
△ RL901	25065269	NRL-1P5A-DC12-36ZA
AC sockets		
△ P902, P903	25050409	NSCT-4P234
Insulating plate		
△	28175137	

NOTE:
THE COMPONENTS IDENTIFIED BY MARK △ ARE CRITICAL FOR RISK OF FIRE AND ELECTRIC SHOCK. REPLACE ONLY WITH PARTS NUMBER SPECIFIED.

PACKING PARTS LIST

REF. NO.	PART NO.	DESCRIPTION
A851	29052164	MASTER CARTON BOX
A852	29091456	PAD, LEFT
A853	29091457	PAD, RIGHT
A854	29100063	750x580mm, POLY-VINYL BAG
A855	282301	SEALING HOOK
A856	29110071	DAMPLON TAPE
A871	261504	PAPER TAPE
ACCESSORY BAG ASS'Y		
A901	29341596	INSTRUCTION MANUAL
A903	2010200	CONNECTION CABLE (3.5 MINI PLUG)
A870	29100097	350x250mm, POLY-VINYL BAG FOR ACCESSORY
A904	29365019	WARRANTY CARD [N]
A905	29358002J	SERVICE STATION LIST [N]
A904	24140200	RC-200S, REMOTE CONTROL UNIT
A905	3010054	UM-3, TOW BATTERIES

NOTE [N]: ONLY U.S.A. MODEL

SCHEMATIC DIAGRAM MODEL P-301

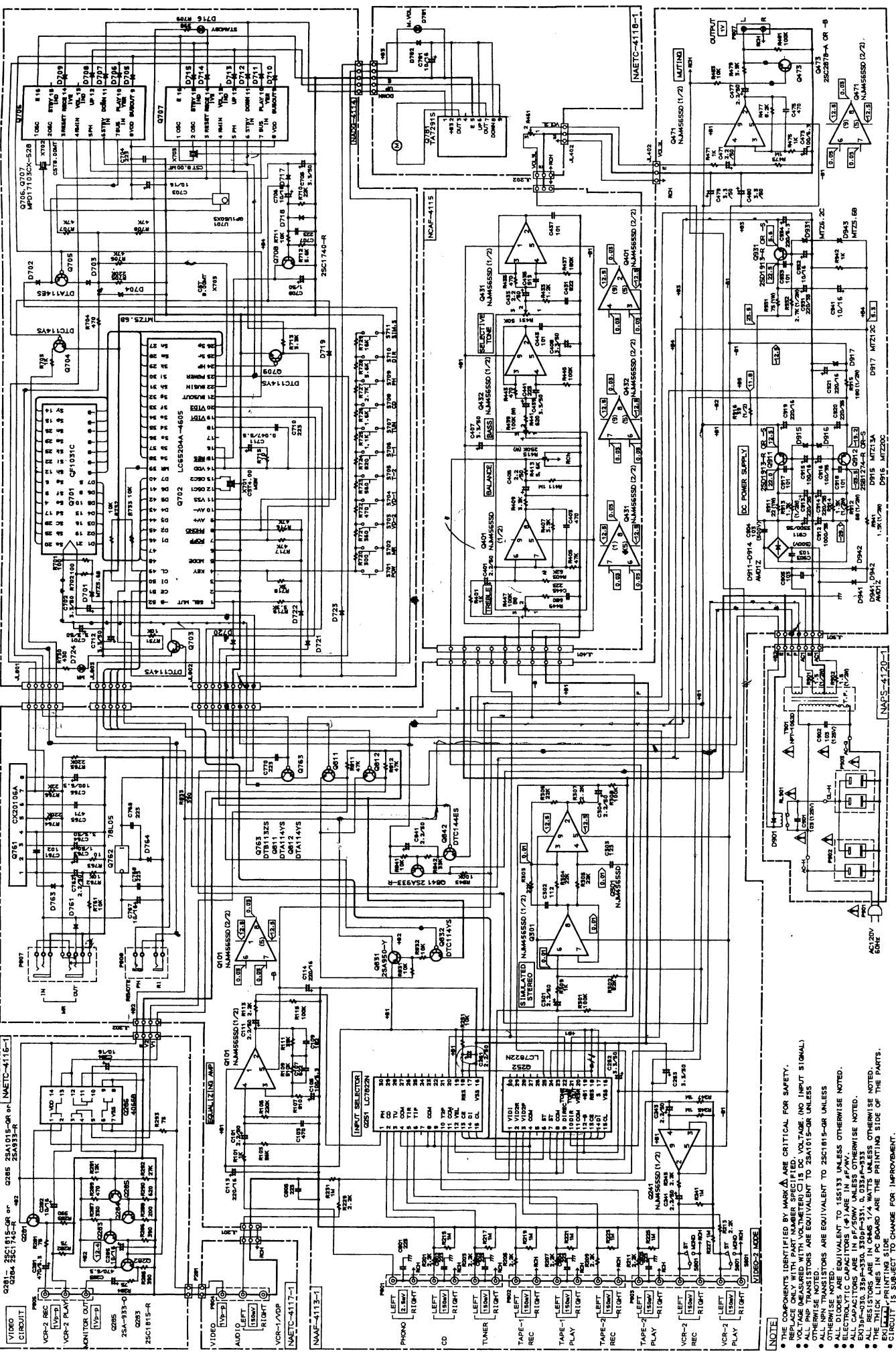

- NOTE**
- THE COMPONENTS IDENTIFIED BY MARK **A** ARE CRITICAL FOR SAFETY.
 - REPLACE ONLY WITH PART NUMBER SPECIFIED IS DC VOLTAGE (NO INPUT SIGNAL).
 - OTHERWISE NOTED CAPACITORS ARE EQUIVALENT TO 25A1015-OR UNLESS OTHERWISE NOTED.
 - ALL NPN TRANSISTORS ARE EQUIVALENT TO 2SC1815-OR UNLESS OTHERWISE NOTED.
 - ALL PNP TRANSISTORS ARE EQUIVALENT TO 2SA1815-OR UNLESS OTHERWISE NOTED.
 - ALL CAPACITORS ARE IN P.F./50V UNLESS OTHERWISE NOTED.
 - ALL RESISTORS ARE IN OHMS UNLESS OTHERWISE NOTED.
 - THE THICK LINES IN PC BOARD ARE THE PRINTING SIDE OF THE PARTS.
 - CIRCUIT IS SUBJECT TO CHANGE FOR IMPROVEMENT.

SYSTEM CONNECTIONS

Note to CATV system installer:

This reminder is provided to call the CATV system installer's attention to Article 820-22 of the NEC that provides guidelines for proper grounding and, in particular, specifies that the cable ground shall be connected to the grounding system of the building, as close to the point of cable entry as practical.

General

Do not plug in the power cord until all connections have been made. Also be sure to perform left and right channel connections properly.

NOTE:
For use with a graphic equalizer. The power cords of the tuner should be connected to the graphic equalizer.

